

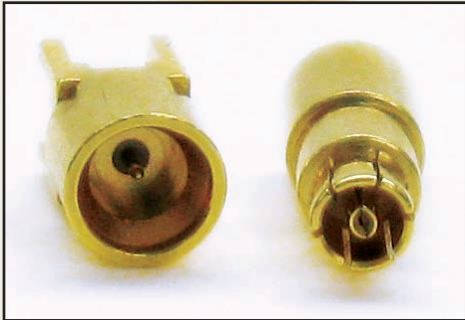

Phoenix SMPM Connectors

-Subminiature size for extreme high-density applications

Product Description



30% smaller than Phoenix's SMP blindmate connectors, the SMPM series provide a smaller lighter-weight solution in high-performance applications where space is a premium. Connectors are designed for rugged environments and feature snap-in interconnects allowing control while mating multiple connectors.

All products manufactured to Mil-Std-348.

Features

- Superior electrical performance from DC to 26.5 GHz.
- Snap feature for quick mating and reduced assembly time.
- Axial alignment reduces stress from multiple blindmate interconnects.
- Gang mating possible. Compensates for up to .010" radial and axial misalignment (when used with an adapter).
- Center-to-Center spacing of .135".

Applications

- Blindmate telecommunications.
- Phased arrays.
- Ship and ground radar.
- Military.
- Active antennas.
- Airborne platforms.
- Satellite communications.

Connector Types (Full Detent And Smooth Bore)

- PCB: Subminiature vertical and right angle plugs.
- Jack-to-Jack: jack-to-jack adapter.
- Cabled: Right angle cable and subminiature straight jack cable.
- Edge Mount: Subminiature edge mount plug.
- Surface Mount: Subminiature vertical surface mount plug.

The Phoenix Company of Chicago, Inc. • 555 Pond Drive, Wood Dale, IL 60191 USA

Tel: (630) 595-2300 • Fax: (630) 595-6579

www.phoenixofchicago.com



The Phoenix Company of Chicago and its affiliates have manufacturing facilities in the United States, Mexico, and China.

Phoenix SMPM Connectors

-Subminiature size for extreme high-density applications

Materials

Male Bodies- Stainless Steel Per QQ-S-763.

Female Bodies- Beryllium Copper Per ASTM-B-196.

Insulators- Teflon (PTFE) Per ASTM-D-1710.

Contacts: Male- Brass ASTM-B-16, Alloy 36000.

Female- Beryllium Copper Per ASTM-B-196.

Plating:

Gold Per Mil-G-45204.

Copper Per Mil-C-14550.

Nickel Per QQ-N-290.

Passivate Per ASTM-A-380.

Finishes (Add Letter To End Of Part Number)

“A”: Body- .000050 Min. Gold Over .000050 Nickel.

“P”: Body- Passivated.

Contact- .000050 Min. Gold Over Nickel.

Other Metal Parts: Gold Plated Or Passivated To Meet The Environmental Requirements.

Mating Characteristics

Engagement & Disengagement Forces	Full Detent	Smooth Bore
Engagement	3.5 LBS.	1.5 LBS.
Disengagement	5 LBS.	1.5 LBS.
Endurance	100	1,000

Electrical

Impedance: 50 Ohms.

Frequency Range: DC To 26.5 GHz. (Max. Frequency Depends Upon Cable And Component Selection).

Voltage Rating: 335 Volts RMS @ Sea Level, 65 Volts RMS @ 70,000 Feet.

Insulation Resistance: 1,000 Megohms Min.

Temperature Rating: -65°C to +165°C.

DWV: 325 Volts RMS.

Contact Resistance: Center Contact: 6.0 Milliohms. Outer Contact: 2.0 Milliohms.

VSWR: 1.20 Max. @ DC To 18 GHz.

1.35 Max. @ 18 To 26.5 GHz.

Corona Level: 70,000 Ft. – 190 Volts.

RF Leakage: -80dB To 3 GHz, -65 dB From 3 To 26.5 GHz.

The Phoenix Company of Chicago, Inc. • 555 Pond Drive, Wood Dale, IL 60191 USA

Tel: (630) 595-2300 • Fax: (630) 595-6579

www.phoenixofchicago.com

INTERFACE DESIGN STANDARD		 22 GREAT HILL ROAD, NAUGATUCK, CT. 06770 PHONE: (203) 729-9090 FAX: (203) 723-1794	REV	DESCRIPTION	DATE	APPR
IDS-132			A	PER ECN 9641	11/19/08	JEM
PAGE 1 OF 2	DATE: 4/16/07		B	PER ECN 9715	2/13/09	JEM
DRAWN: ALS	APPROVED: JEM					

DESCRIPTION: 132 SERIES, SMPM

MECHANICAL

MATERIALS MALE BODIES- STAINLESS STEEL PER QQ-S-763. FEMALE BODIES- BERYLLIUM COPPER PER ASTM-B196. INSULATORS - TEFLON (PTFE) PER ASTM-D1710. CONTACTS: MALE - BRASS ASTM-B-16, ALLOY 36000 FEMALE - BERYLLIUM COPPER PER ASTM-B196.	PLATING: GOLD PER MIL-G-45204. COPPER PER MIL-C-14550. NICKEL PER QQ-N-290. PASSIVATE PER ASTM-A380.
--	--

FINISHES <ADD LETTER TO END OF PART NUMBER>

'A': BODY - .000050 MIN. GOLD OVER .000050 NICKEL
'P': BODY - .PASSIVATED
CONTACT - .000050 MIN. GOLD OVER NICKEL
OTHER METAL PARTS:
GOLD PLATED OR PASSIVATED TO MEET THE ENVIRONMENTAL REQUIREMENTS.

MATING CHARACTERISTICS

ENGAGEMENT & DISENGAGEMENT	FULL DETENT	SMOOTH BORE
ENGAGEMENT	3.5 LBS.	1.5 LBS.
DISENGAGEMENT	5 LBS.	1.5 LBS.
ENDURANCE:	100	1000

ELECTRICALS

IMPEDANCE: 50 OHMS.
FREQUENCY RANGE: DC TO 26.5 GHz. <MAX. FREQUENCY DEPENDS UPON CABLE AND COMPONENT SELECTION>.
VOLTAGE RATING: 335 VOLTS RMS @ SEA LEVEL, 65 VOLTS RMS @ 70,000 FEET.
INSULATION RESISTANCE: 1000 MEGOHMS MIN.
TEMPERATURE RATING: -65°C TO +165°C
DWV: 325 VOLTS RMS.
CONTACT RESISTANCE: CENTER CONTACT: 6.0 MILLIOHMS.
OUTER CONTACT: 2.0 MILLIOHMS.
VSWR: 1.20 MAX. @ DC TO 18 GHz.
1.35 MAX. @ 18 TO 26.5 GHz.
CORONA LEVEL: 70,000 FT. - 190 VOLTS
RF LEAKAGE: -80dB TO 3 GHz, -65 dB FROM 3 TO 26.5 GHz.

ENVIRONMENTAL

VIBRATION: MIL-STD-202, METHOD 204, TEST CONDITION D.
SHOCK: MIL-STD-202, METHOD 213, TEST CONDITION A.
THERMAL SHOCK: MIL-STD-202, METHOD 107, TEST CONDITION B, HIGH TEMPERATURE 165°C.
CORROSION: MIL-STD-202, METHOD 101, TEST CONDITION B.
MOISTURE RESISTANCE: MIL-STD-202, METHOD 106, OMIT STEP 7b.

INTERFACE DESIGN STANDARD	
IDS-132	
PAGE 2 OF 2	DATE: 4/16/07
DRAWN: ALS	APPROVED: JEM

PALEO CONNECTOR

22 GREAT HILL ROAD, NAUGATUCK, CT. 06770
 PHONE: (203) 729-9090 FAX: (203) 723-1794

REV	DESCRIPTION	DATE	APPR
A	PER ECN 9641	11/19/08	JEM
B	PER ECN 9715	2/13/09	JEM

DESCRIPTION: 132 SERIES, SMPM

DIMENSIONS ARE TO MIL-STD-348A (328-3)

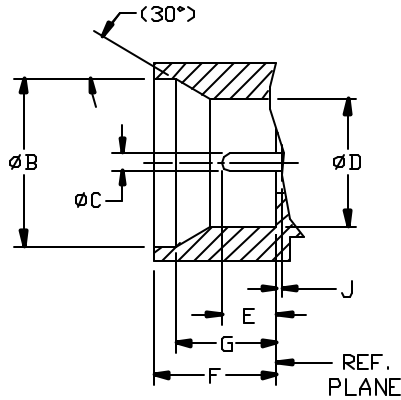

SMOOTH BORE
 MALE INTERFACE
 (PER 328-3)

LTR	INCH	[mm]
B	.115 .111	2.92 2.82
C	.013 .011	0.33 0.28
D	.088 .086	2.24 2.18
E	.045 .030	1.14 0.76
F	.084 .082	2.13 2.08
G	.072 .062	1.83 1.57
J	.000 .000	-- --

DIMENSIONS ARE TO MIL-STD-348A (328-2)

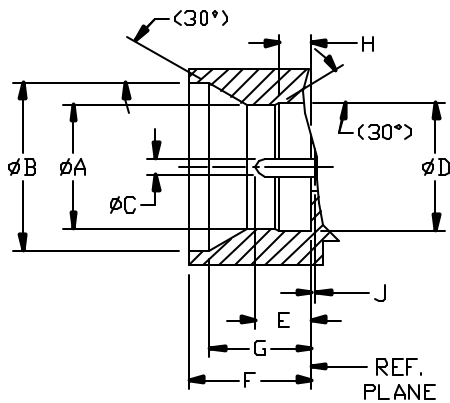

FULL DETENT
 MALE INTERFACE
 (PER 328-2)

LTR	INCH	[mm]
A	.085 .083	2.16 2.11
B	.115 .111	2.92 2.82
C	.013 .011	0.33 0.28
D	.088 .086	2.24 2.18
E	.045 .030	1.14 0.76
F	.084 .082	2.13 2.08
G	.072 .062	1.83 1.57
H	.023 .021	0.58 0.53
J	.000 .000	-- --

DIMENSIONS ARE TO MIL-STD-348A (328-1)

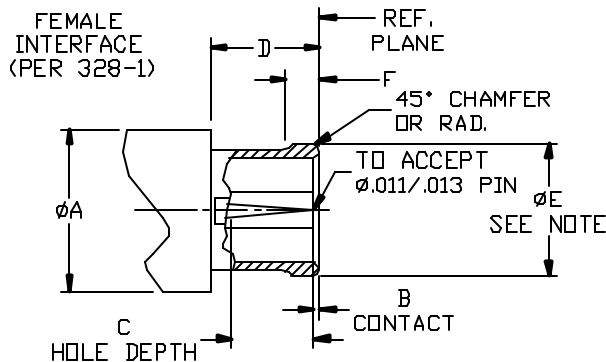

LTR	INCH	[mm]	SUFFIX
A	.110	2.79	MAX.
B	.008 .000	0.20 0.00	--
C	.050	1.27	MIN.
D	.068	1.73	MIN.
E	.095	2.41	MAX.
F	.023	0.58	MAX.

NOTE: FEATURES TO MEET MECH./ELECTRICAL REQUIREMENTS WHEN MATED WITH SMPM MALE INTERFACE.